

GTCL

Bran cutting machine

The GTCL bran crusher reduces the particle size of the incoming product to 500/600 microns in a single pass, resulting in a homogeneous output. Golfetto Sangati, unique in the world, has been producing its shredder for decades, used also for other applications. The current market demand has led Golfetto Sangati to reengineer the GCTL by equipping it with a 98-bladed steel shaft (tempered steel blades) with a maximum rotation speed of 3500 rpm. The shaft is inserted inside a casing that rotates in the opposite direction, guaranteeing the highest grinding performance and facilitating the cleaning effect ensured by a rotating brush made of nylon threads and a pneumatic brush.

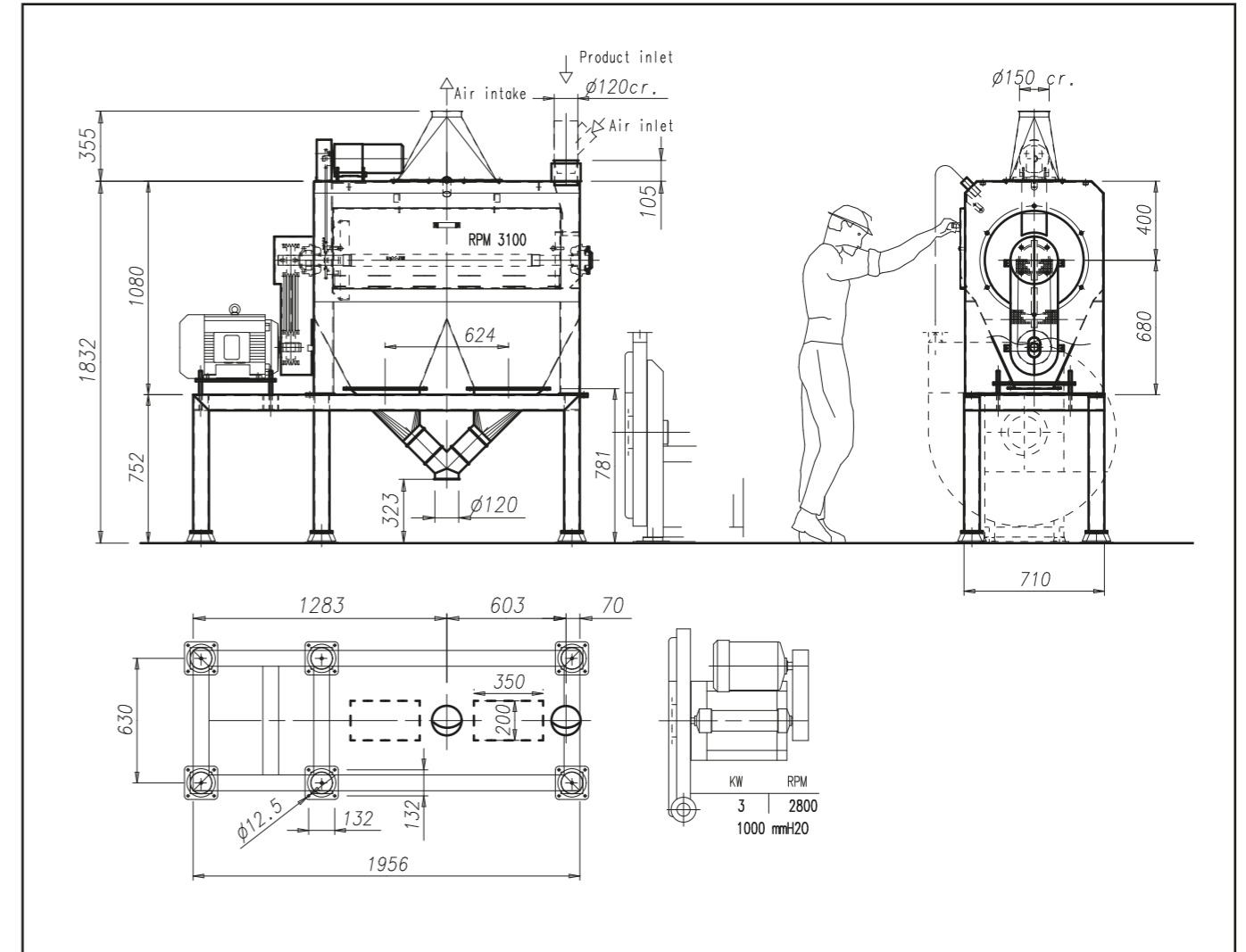
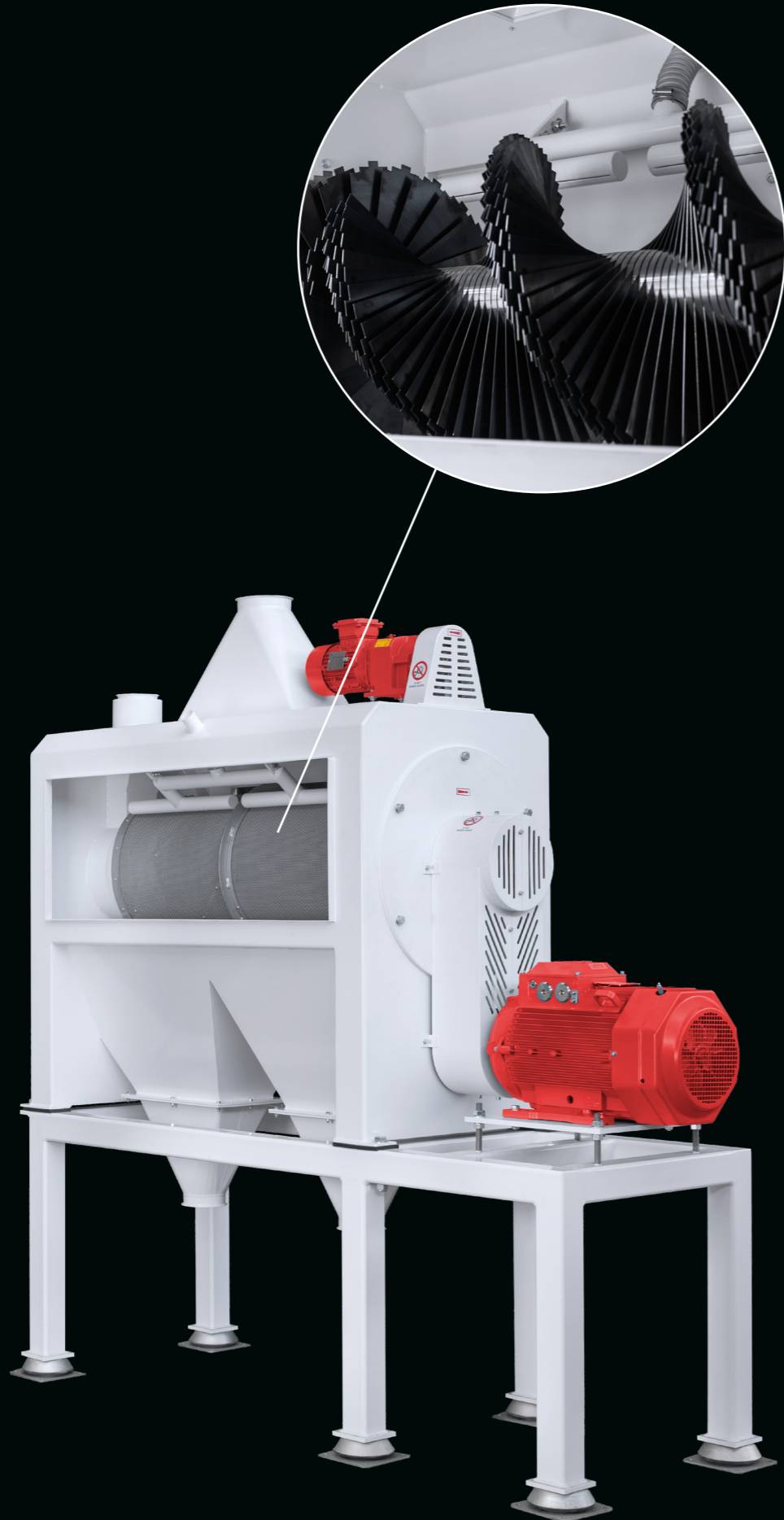

Capacity t/h	Cover ØxL	Air intake		Rotor motor power kW	Cover motor power kW	Weight Kg
		m ³ /1'	mmH2O			
1	410x1000	15	70	18.5	0.37	1300

Units = mm